

Ferrite Magnet Steel Chassis Driver



Specifications

General Specifications

Nominal diameter.....	457 mm/18 in
Power rating.....	400 W(AES)
Nominal impedance.....	8Ω
Sensitivity.....	95 dB
Frequency range.....	30-200 Hz
Chassis type.....	Heavy Duty Stamp Steel
Magnet type.....	Ferrite
Magnet weight.....	2.56 kg/ 90.3 oz
Voice coil diameter.....	76.2 mm/3.0 in
Coil material.....	SV-W
Former material.....	Glass fiber
Cone material.....	Paper
Surround material.....	Cloth
Suspension.....	Single
X-max.....	5 mm/0.2 in
Gap depth.....	10 mm/0.39 in
Voice coil winding width.....	20 mm/0.79 in
Net Weight.....	8.5 kg/18.7 lb
Packing Dimension WxDxH (mm)	505mm x 505mm x 250mm
Shipping Weight.....	10.1 kg/22.3 lb

Small Signal Parameters

Re.....	6.0Ω
Fs.....	33 Hz
Mms.....	157.04 g/5.54 oz
Mmd.....	134.21 g/4.73 oz
Qms.....	8.25
Qes.....	0.53
Qts.....	0.50
Vas.....	284.36 lt/10.04 ft ³
Bl.....	19.22 Tm
Cms.....	8.4e-05 m/N
Rms.....	12.46 Ns/m
Le (at 1kHz).....	0.69 mH

Features

- 3" Voice Coil
- 1600 Watts Peak Power Handling
- Ferrite Magnetics
- Precision Circular Wire Geometry
- Stamped Steel Chassis

Applications

The P Audio E18-400S NEW is a high output low frequency transducer. The E18-400S NEW is an upgraded design that features many of P Audio's new technologies and performance upgrades. The 18 inch (457mm) diameter piston will produce extremely high sound pressure levels at very low frequencies and is ideal for high level deep bass and sub woofer response in both live sound and recorded music venues. The operating bandwidth of the E18-400S NEW is 30Hz to 200Hz. The transducer uses high energy ferrite magnetics to achieve a very high acoustic output to weight ratio.

The E18-400S NEW employs a medium format 3 inch (76.2mm) diameter voice coil that provides an AES rated 400 watts of continuous power handling and a full 1600 watts of peak rated power handling when sufficient amplifier headroom is available. The E18-400S NEW utilizes P Audio's under damper venting technology to improve transducer air flow and reduce turbulence under the damper and around the voice coil.

The voice coil design is bobbin wound geometry with P Audio's precision round wire technology to maximize system conversion efficiency.

The suspension has been designed specifically for high linear displacement and extended low frequency response.

The transducer chassis is a heavy gauge stamped steel design that insures a very high degree of structural integrity.

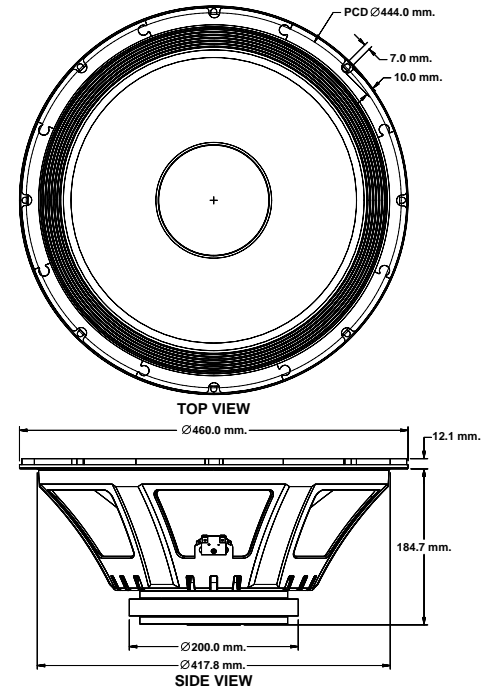

Frequency Response and Impedance Curves

