



GM SERIES

GM12-100F

Low Frequency Ferrite Woofer



Features

- 4" Large Format Voice Coil
- 3600 Watts Peak Power Handling
- 97 dB Sensitivity
- FEM Designed Ferrite Magnetics
- Precision Round Wire Inside/Outside Coil Design
- Triple Aluminium Demodulation Rings

Applications

The P. Audio 'Golden Master' GM12-100F is the intersection of advanced design and state of the art manufacturing. The GM12-100F is a 12 inch (305mm) low frequency transducer for high performance professional audio. The 4 inch (101.6mm) inside/outside wound voice coil is designed for superior reliability and excursion, featuring low weight, high temperature copper clad aluminium wire and extended winding length. The weight-optimized ferrite magnetics maximize the coil's strengths by providing strong magnetic flux across its whole range of movement. This keeps coil motion faithful to the audio signal without distorting. Aluminium 'demodulation' rings negate inductance effects in the motor, further improving the fidelity of coil movement.

The ferrite magnet structure cooperates with a carefully optimized venting system on the bottom of the sleek Golden Master chassis to control airflow around the voice coil. This cools the durable design to further levels of reliability without losing sensitivity – the GM12-100F is rated at 3200 W peak power handling/ 800 W AES continuous power handling with nominal sensitivity of 97 dB.

Linear and symmetrical stiffness behavior of the suspension compliments linear coil motion. The GM12-100F's large diameter spider is a durable silicone laminate design that provides symmetrical displacement and reliable voice coil positioning even after hours at high power levels. The cone features a proprietary double-roll cloth surround. The perfect match of material and geometry mean ultra-low distortion of cone movement and ultra-low distortion of sound. Coating keeps the cone rigid and waterproof during operation, while low moving mass has been optimized for high performance 12" two-way designs.

The ideal application for the GM12-100F is in very high performance sound reinforcement and large format public address systems. It is ideal for use in a well-tuned vented enclosure in a range of configurations – general purpose sound reinforcement systems, mid-bass applications and floor monitors. Performance is optimized when using a high pass 4th order Butterworth filter tuned near the enclosure vent frequency. The GM12-100F offers a 60-2500Hz useable bandwidth, though the actual crossover frequency will be determined by the driver and horn combination in the user's system.

Frequency response and Impedance curve

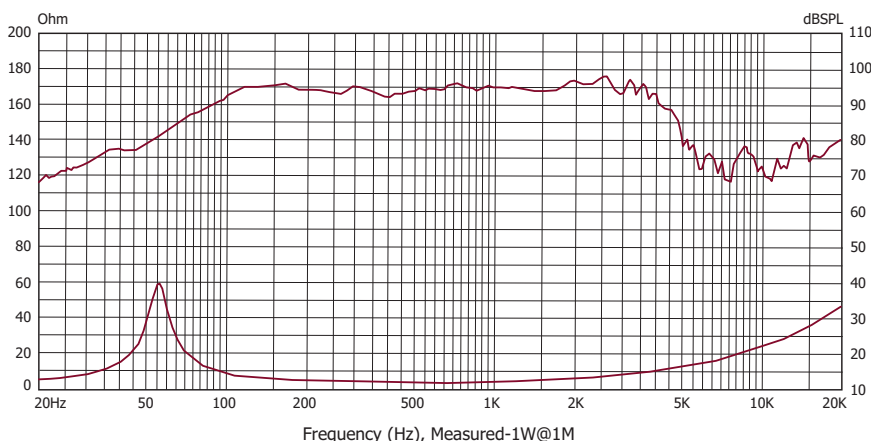

General Specification

Nominal diameter	305 mm / 12 in
Peak Power	3200 W
AES Power	800 W
Nominal impedance	8 Ohm
Sensitivity (1W/1m)	97 dB
Frequency range	60 - 2500 Hz
Chassis type	Cast Aluminium
Magnet type	Ferrite
Magnet weight	3.56 kg / 125.7 oz
Voice coil diameter	101.6 mm / 4 in
Coil material	Round Copper Clad Aluminium Wire
Former material	Glass fiber
Cone material	Paper
Surround material	Cloth
Suspension	Silicone Impregnated Spider
Xmax	2.55 mm / 0.10 in
Gap depth	10 mm / 0.39 in
Voice coil winding width	15.1 mm / 0.59 in
Unit weight	11.1 kg / 24.5 lb
Shipping weight	12 kg / 26.5 lb
Packaging dimension WxDxH	355x355x190 mm 14x14x7.5 in

Thiele Small Parameters

Fs	56 Hz
Re	5.4 Ohm
Qms	5.97
Qes	0.38
Qts	0.35
Bl	18.99 Tm
Mms	72.15 g / 2.55 oz
Mmd	65.11 g / 2.30 oz
Vas	44.70 lt / 1.58 cu.ft ³
Sd	531 cm ²
Le	0.55 mH
Cms	1.1e - 04 m/N
Rms	4.25 Ns/m

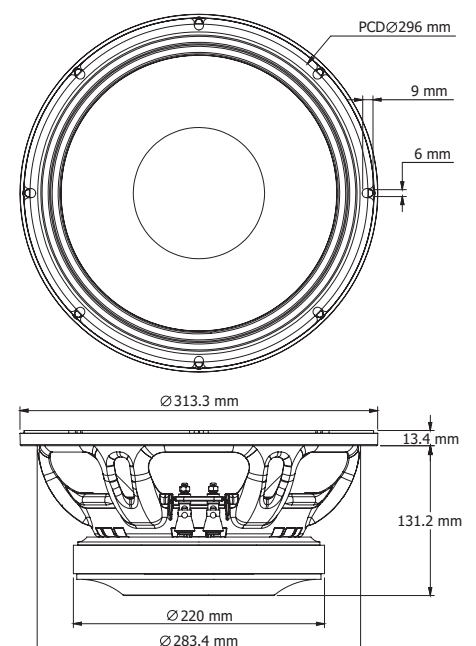

P.AUDIO SYSTEM CO.,LTD.