

Neodymium Magnet Die-cast Chassis Driver



Features

- 4.5" Very Large Format Voice Coil
- 6800 Watts Peak Power Handling
- Active Balanced Cooling
- Neodymium Magnetics
- Square Wire Inside/Outside Coil Design
- Double Spider Suspension
- Integrated Demodulation Rings
- Die Cast Aluminum Chassis

Applications

The SD18-1700N is a very high output low frequency transducer. The 18 inch (457mm) diameter piston will produce extremely high sound pressure levels at very low frequencies and is ideal for high level deep bass and sub woofer response in both live sound and recorded music venues. The operating range is 30Hz to 200Hz. The transducer uses high energy neodymium magnetics to achieve a very high acoustic output to weight ratio.

The SD18-1700N employs a large 4.5 inch (114.3mm) diameter voice coil that provides an AES rated 1700 watts of continuous power handling and a full 6800 watts of peak rated power handling when sufficient amplifier headroom is available. It is recommended that the transducer be loaded into a properly designed vented enclosure and suitable active high pass filtering be employed if extremely high power levels are expected at low frequencies. The SD18-1700N utilizes P Audio's Auto Balanced Cooling (ABC) technology to not only improve transducer power handling and reliability but to also increase power compression performance by carefully balancing and directing airflow to critical areas.

The voice coil design is an "inside/outside" geometry with P Audio's square wire technology to improve conversion efficiency and provide a very large cross-sectional area for superior cooling.

System linearity is achieved by employing magnetic flux demodulation devices in the structure to increase fidelity and sonic accuracy. The system suspension has been designed specifically for high linear displacement and extended low frequency response. The double spider design insures very high displacement and linear response while maintaining excellent control. The cone has been treated with a conformal coating designed to provide additional mechanical damping and moisture resistance.

The transducer chassis is a die cast aluminum design that insures a very high degree of structural integrity.

Specifications

General Specifications

Nominal diameter.....	457 mm/18 in
Power rating.....	1700 W(AES)
Nominal impedance.....	8Ω
Sensitivity.....	98 dB
Frequency range.....	30-200 Hz
Chassis type.....	Cast aluminum
Magnet type.....	Neodymium
Magnet weight.....	0.62 kg/21.9 oz
Voice coil diameter.....	114.3 mm/4.5 in
Coil material.....	SV-SQ
Former material.....	Glass fiber
Cone material.....	Paper
Surround material.....	Cloth
Suspension.....	Double
X-max.....	7.5 mm/0.29 in
Gap depth.....	15.0 mm/0.59 in
Voice coil winding width.....	30.0 mm/1.18 in
Net Weight.....	12.4 kg/27.3 lb
Packing Dimension WxDxH (mm)	505mm x 505mm x 285mm
Shipping Weight.....	14.0 kg/30.9 lb

Small Signal Parameters

Re.....	5.2Ω
Fs.....	44 Hz
Mms.....	302.0 g/10.65 oz
Mmd.....	277.35 g/9.78 oz
Qms.....	10.62
Qes.....	0.39
Qts.....	0.38
Vas.....	88.58 lt/3.13 ft³
Bl.....	33.7 Tm
Cms.....	4.2e-05 m/N
Rms.....	7.86 Ns/m
Le (at 1kHz).....	1.13 mH

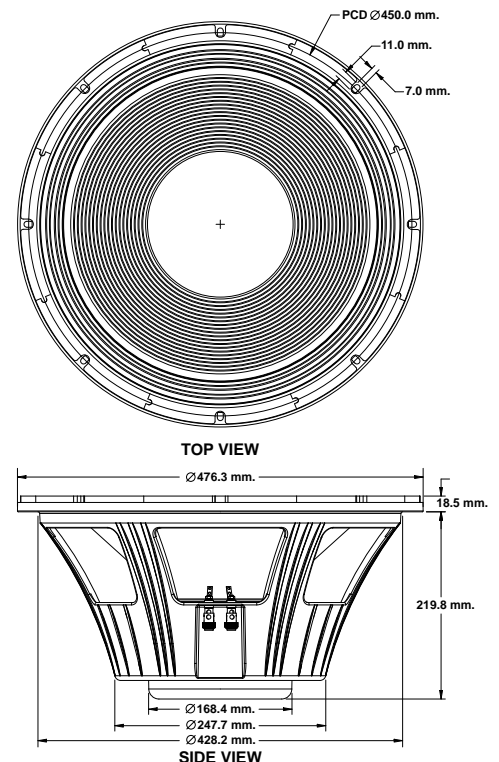

Frequency Response and Impedance Curves

